

Series 612

- Downstream pressure control valve
- Compact design
- Very fast operation
- High-performance, integrated controller

Body material

aluminum or stainless steel

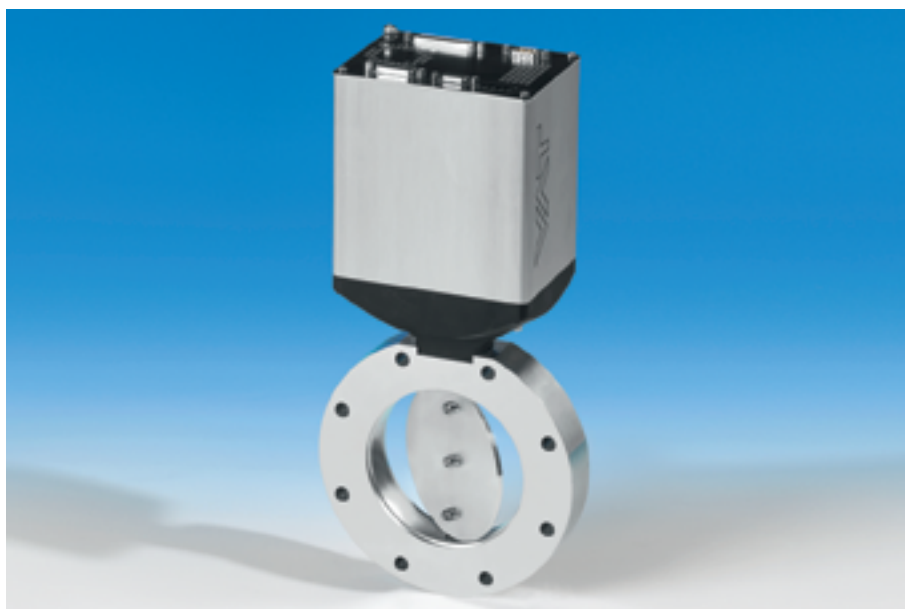

Valve with integrated controller

DN		Ordering numbers							
		aluminum				stainless steel			
mm	inch	ISO-KF		ISO-F		ISO-KF		ISO-F	
40	1½	61232-KA	x y			61232-KE	x y		
50	2	61234-KA	x y			61234-KE	x y		
63	2½			61236-PA	x y			61236-PE	x y
80	3			61238-PA	x y			61238-PE	x y
100	4			61240-PA	x y			61240-PE	x y
160	6			61244-PA	x y			61244-PE	x y
200	8			61246-PA	x y			61246-PE	x y

optional controller configurations

SPS = ±15VDC Sensor Power Supply

PFO = Power Failure Option
(valve closes or opens automatically at power failure)

x	y				
G = basic version		1)	2)	1)	2)
A = with SPS		G = RS232	1	J = RS485	1
H = with PFO		H = RS232	2	K = RS485	2
C = with SPS and PFO		C = Logic	1	Y = Ethernet	1
		E = Logic	2	Z = Ethernet	2
		P = DeviceNet®	1	L = CC-Link	1
		Q = DeviceNet®	2	N = CC-Link	2
		D = Profibus	1	I = EtherCAT	1
		F = Profibus	2	X = EtherCAT	2
				1) = interface	
				2) = quantity of sensors	

Example: 61240-PAGG
= aluminum valve
with ISO-F DN 100 flanges,
RS232 interface, for 1 sensor

Accessories

Designation	Ordering No.
CV software including service cable ³⁾	600SV-99LB
CPA software including service cable ³⁾	600SP-99LB
Service box 2 (standard version with 1.5 m cable) ³⁾	601BS-29NN
Control panel for installation into 19" rack, including 5 m cable ³⁾	602BS-29LE
Connector kit for valves with RS232, RS422, RS485 or Logic interface consisting of counter plugs for INTERFACE, SENSOR and POWER connections	242411
Connector kit for valves with fieldbus consisting of counter plugs for SENSOR and POWER connections	242410
AC power supply unit (input: 100 - 240 VAC, output: 24 VDC / 4A)	249775

³⁾ Details see chapter «Pressure controller»

Feedthrough

Rotary feedthrough FKM (VITON)
(double seal)

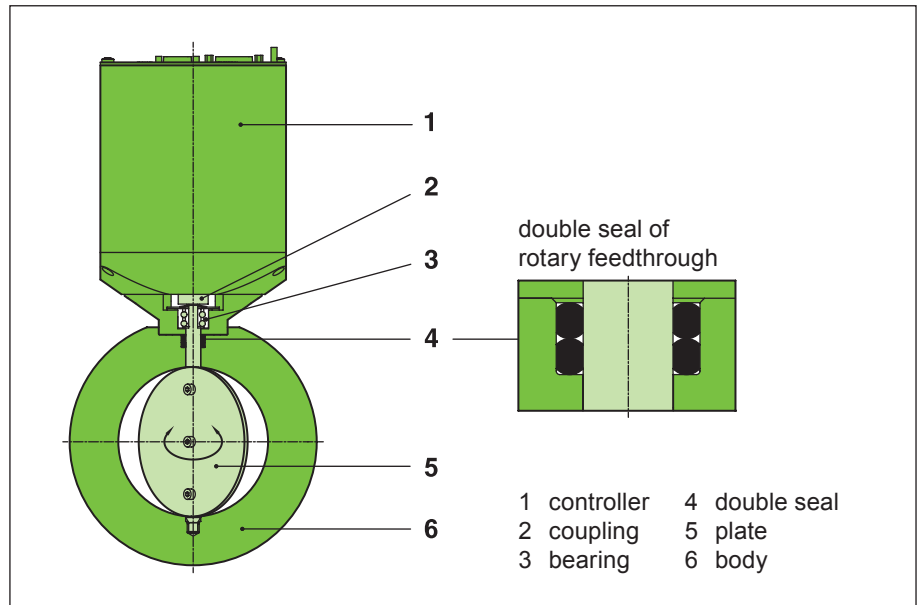

Features

- Very fast operation
- Extremely short control response times
- Integrated controller
- Automatic service signal (contamination)
- Position indication
- Actuator unit easy to remove/mount
- Service port (computer or service box 2 connection)
- Excellent resistance to contaminating processes

Function

The valve plate acts as a throttling element and varies the conductance of the valve opening. The integrated controller calculates the required plate position to achieve the setpoint pressure. See also principle drawing on page 225. Actuation is performed by a stepper motor. An encoder monitors the position. This principle ensures very fast and accurate process pressure control even in demanding contaminating processes.

Control range

VAT provides the «CONTROL VALVE EVALUATION TOOL» to help you select the product most suitable for your process. The tool is available on our website www.vatvalve.com → Country → Control Valve Evaluation Tool for free use.

Technical data

Actuator unit with controller	Power consumption	+ 24 VDC (±10%) @ 0.5 V pk-pk max. 38 W max. (controller + motor) 10 W max. for Power Failure Option 36 W max. for Sensor Power Supply
	Sensor supply	24 VDC or ±15 VDC
	Sensor input	
	- Signal voltage	0 - 10 VDC linear with pressure
	- Input resistance	Ri = 100kΩ
	- Resolution	0.23 mV
	- Sampling rate	10 ms
Control accuracy	0.1% of maximum sensor range	
Position resolution	20000 (steps = 0 - 90° rotation)	
Ambient temperature	50°C max. (<35°C recommended)	
Valve unit	Pressure range	1 · 10 ⁻⁸ mbar to 1.2 bar (abs)
	Leak rate to the outside	1 · 10 ⁻⁹ mbar ls ⁻¹
	Cycles until first service ¹⁾	2 million
	Temperature ²⁾	
	- Valve body	≤ 150°C
	- Actuator	≤ 50°C
	- Ambient	≤ 50°C
	Mounting position	any
	Material in vacuum	
	- Valve body, plate	EN AW-6082 (3.2315) or AISI 316L (1.4404)
- Shaft	AISI 316L (1.4404)	
- Other parts	iglidur [®] X, AISI 316L (1.4404)	
- Feedthrough seals	FKM (VITON)	

¹⁾ Unheated and under clean conditions

²⁾ Maximum values: depending on operating conditions and sealing materials

DN (nominal I. D.)		conductance in open position (molecular flow)	minimum controllable conductance (molecular flow)	max. differential pressure	typical closing / opening time	weight (approx.)			
						aluminum		stainless steel	
mm	inch	ls ⁻¹	ls ⁻¹	mbar	s	kg	lbs	kg	lbs
40	1½	80	0.25	1000	0.3	2.1	4.6	2.6	5.7
50	2	150	0.3	1000	0.3	2.4	5.3	3	6.6
63	2½	360	0.45	1000	0.3	2.6	5.7	4.1	9
80	3	850	0.65	1000	0.3	2.8	6.2	4.7	10.4
100	4	1400	0.85	800	0.3	3	6.6	5	11.
160	6	3800	1.7	300	0.3	4.2	9.3	7.2	15.9
200	8	7800	2.8	150	0.3	4.7	10.4	8.1	17.9

Pressure controller

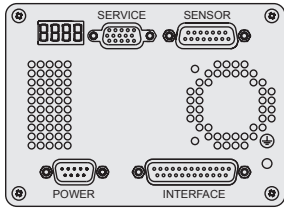

RS232, Logic, RS422, RS485

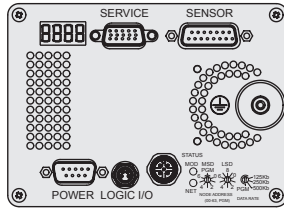

DeviceNet®

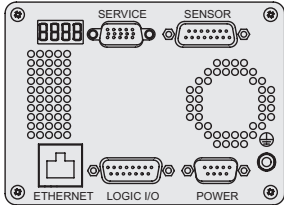

Ethernet

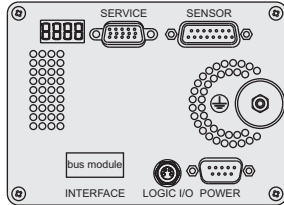

Profibus, CC-Link, EtherCAT

Features

- Very fast and accurate pressure control
- Automatic learning of system parameters
- Hold function for plasma ignition
- Valve position control
- Remote control
- Information display
- Inputs for 1 or 2 linear pressure sensors (capacitance manometers)
- Service interface for local operation
- Closing or opening of the valve at power failure (option)

Dimensions

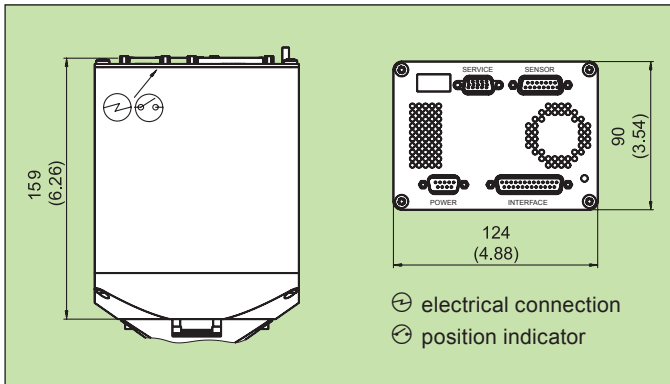

Electrical connections

	connection	type
POWER	power input	DB-9 male
SENSOR	sensor input	DB-15 female
	sensor power supply	
INTERFACE	RS232, Logic, RS422, RS485	DB-25 female
	DeviceNet®	micro-style male
	Ethernet	RJ 45
Bus modules	Profibus	DB-9 female
	CC-Link	5-pole terminal screw
	EtherCAT	2 x RJ 45

Pressure control

The controller ensures very fast and accurate pressure control. By operating the LEARN function — needs to be done only once at start-up — the system parameters are automatically determined.

Due to the adaptive algorithm the controller continuously adapts to the process conditions (species of gas, gas flow) and thus ensures optimum pressure control at any time.

Valve position control

In position control mode the valve plate can be moved to any position.

Display

Status and position are displayed by means of 4 bright digits.

Remote control

The valve can be controlled by a host computer via RS232, RS422, RS485, Logic, DeviceNet®, Ethernet, Profibus, CC Link or EtherCAT interface.

The RS232 interface and the field busses also have digital inputs to close and open the valve. In addition, digital outputs are available for «open» and «closed» (status of valve).

Control via Logic interface performs via digital and analog inputs and outputs.

Service port

The valve has a service port (RS232) for connecting a computer or a service box. VAT can provide two software versions which, independent of the hoster computer, allow a variety of functions.

For connecting the computer to the valve, a special cable designed by VAT is required.



Basic version VAT Control View (CV software)



- Setup
- Operation
- Monitoring
- Diagnostics

The basic software (CV) and the drawing for the connecting cable may be downloaded for free from our Website www.vatvalve.com → Country → Services → Downloads.

The software and the cable may also be ordered from VAT. For details see price list.

Extended version VAT Control Performance Analyzer (CPA software)



- Setup
- Operation
- Monitoring
- Diagnostics
- Graphical illustration of the pressure behavior
- Programming and recording of sequences
- Several possibilities for data analysis and process optimization

The extended software (CPA) and the connecting cable may be ordered from VAT. For details see price list.

Service box 2 / Control panel

For local operation of valves with integrated controller as an alternative to the computer.



standard service box 2 with cable



control panel with cable for integration into a 19" rack

Power Failure Option (PFO)

This function is optionally available. It closes (to the minimum conductance) or opens the valve automatically at power failure.

Sensor Power Supply (SPS)

Optionally, the valve can be provided with a $\pm 15\text{VDC}$ power supply unit for the sensor/s.

Options

Certain options are not available for some nominal diameters or cannot be combined. Moreover, options can affect the general technical data.



Actuator / controller

- Ultra fast actuator (100 ms)
- Output for control of isolation valve
- Controller with configurable PI parameters
- RS232 interface with 2 analog outputs

Valve

- Sizes DN 25 and DN 250
- Other flanges (JIS, ASA-LP, CF-F)
- Customer specified flanges
- Aluminum hard anodized or nickel-plated
- Other sealing materials
- Heater with insulation (picture) for valve temperatures up to 150°C (for temperatures up to 200°C on request)
- «Combo» body to combine a series 612 control valve with an isolation valve: see series 95, pages 124 - 125

Ordering information for options:

Ordering No. of valve-X (e. g. 61236-PEGG-X, X = valve with heater for 80°C)

Dimensions

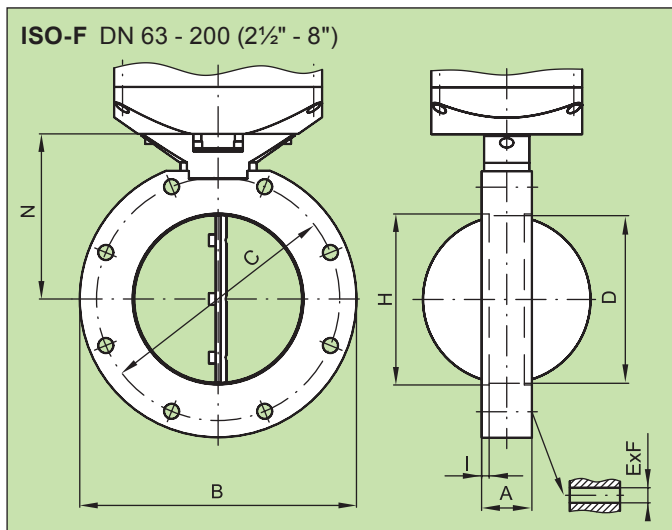
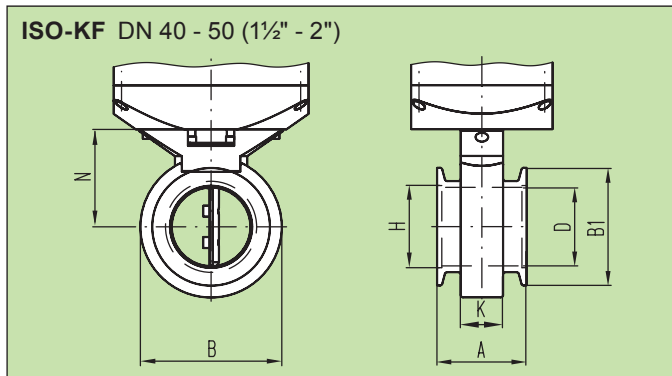

DN	mm inch	40 1½	50 2	63 2½	80 3	100 4	160 6	200 8
A	mm inch	57 2.25	57 2.25	30 1.18	30 1.18	30 1.18	30 1.18	30 1.18
B	mm inch	80 3.15	90 3.54	130 5.12	145 5.71	165 6.5	225 8.86	285 11.22
B1	mm inch	54.9 2.16	74.9 2.95	–	–	–	–	–
C	mm inch	–	–	110 4.33	125 4.92	145 5.71	200 7.87	260 10.24
D	mm inch	40 1.57	50 1.97	63 2.48	80 3.15	100 3.94	150 5.91	200 7.87
ExF	mm inch	–	–	4x9 4x0.35	8x9 8x0.35	8x9 8x0.35	8x11 8x0.43	12x11 12x0.43
H	mm inch	41.3 1.63	52.3 2.06	70 2.76	83 3.27	102 4.02	153 6.02	213 8.39
I	mm inch	–	–	4.5 0.18	4.5 0.18	4.5 0.18	4.5 0.18	4.5 0.18
K	mm inch	27 1.06	27 1.06	–	–	–	–	–
N	mm inch	57 2.24	62 2.44	77.5 3.05	90.5 3.56	98.5 3.88	123.5 4.86	157 6.18

